

Specification

Operating Voltage Range	10 - 30V DC
Current Consumption	See Beacon settings
Operating Temperature	-25°C to +75°C
Monitoring mode	Polarity Reversal
Construction	ABS/Polycarbonate FR Plastic
Termination	Screw terminals for 0,28mm ² to 2,5mm ² conductor

Dimensions

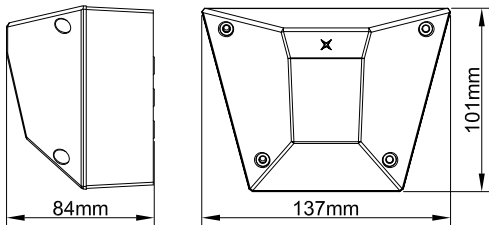

1. Installation

Knockout or drill the required gland holes, and fit cable glands.

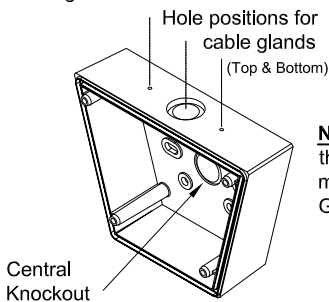

NOTE: Ensure that the IP integrity is maintained during Gland Fitting.

2. Fixing Details

Knockout desired fixing holes, fix base to wall or BESA box. Ensure that the gasket is used.

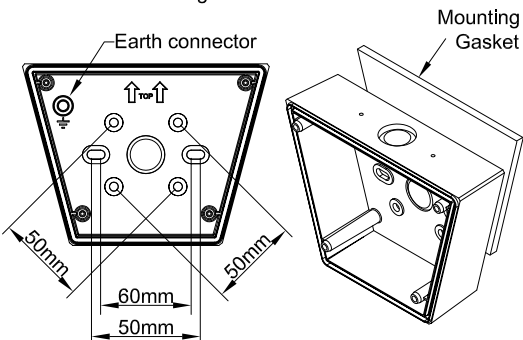

3. Beacon settings



1 = Closed

0 = Open

Set DIL switch to required setting. (Table shown below)

Switch 1	Switch 2	Flash Rate	Current 30V - 10V
open	open	45/min	130-380mA
closed	open	60/min	200-610mA
open	closed	85/min	200-550mA
closed	closed	120/min	240-680mA

4. Connection Details

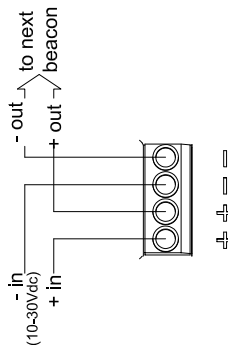

5. Beacon Assembly

Fix the beacon to the base with the screws provided. (Do not over tighten)

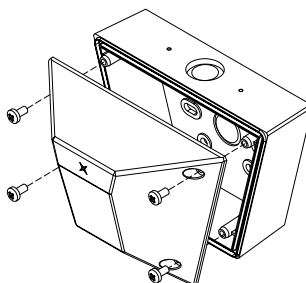

WARNING: High voltage present within this equipment.

Do not remove cover, refer servicing to qualified personnel.