

# Symphoni LX Wall base

## Symphoni LX Wall base (WP)

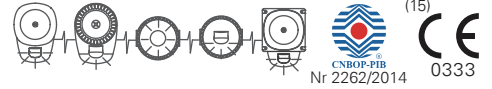

- (EN)** EN54-23 Fire alarm devices visual alarm device for use in & around buildings
- (FR)** Dispositifs incendie EN54-23 dispositifs visuels alarme feu pour utilisation à l'intérieur et autour des bâtiments
- (DE)** EN54-23 Feuermeldevorrichtung Optischer Signalgeber zur Innen-und Aussenmontage
- (PL)** EN54-23 Pożarowe urządzenia alarmowe sygnalizatory optyczne do pomieszczeń i na zewnątrz budynków.
- (IT)** Dispositivi di allarme antincendio EN54-23 dispositivo di allarme visivo per uso all'interno e nelle vicinanze degli edifici

	EN54-23:2010		ABS FR & Polycarbonate
	9 - 60Vdc		Type A (IP21C) & B (IP66)
	-25°C ~ +70°C		1.5W (max)
	2.4m (max)		100mS ON / 900mS OFF 50mS ON / 950mS OFF
	< 120% for 10mS		0.5mm <sup>2</sup> - 2.5mm <sup>2</sup>

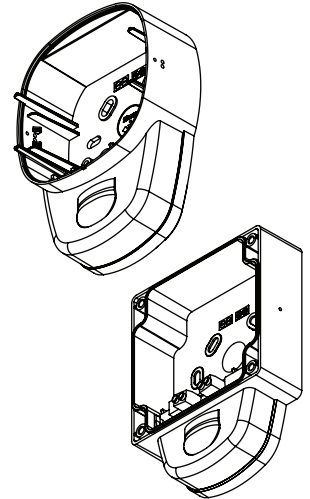

DOP No.: 0333-CPD-075445  
DOP No.: 0333-CPD-075446

	High Power			Low Power	
	1 Hz	0.5Hz	1 Hz	0.5Hz	
	White & Red	W-2.4-7.5 7.5m (135m <sup>3</sup> )	White W-2.4-2.5 2.5m (15m <sup>3</sup> )	Red W-2.4-2.5 2.5m (15m <sup>3</sup> )	
	White Flash Flash Blanc Weisser Blitz	12V 51mA 27mA 24V 25mA 16mA 48V 18mA 11mA	35mA 19mA 16mA 10mA 11mA 9mA		
	Red Flash Flash Rouge Roter Blitz	12V 51mA 27mA 24V 25mA 16mA 48V 18mA 11mA	35mA 19mA 16mA 10mA 11mA 9mA		

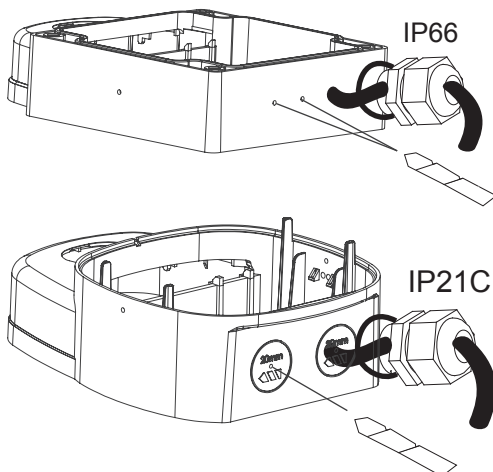
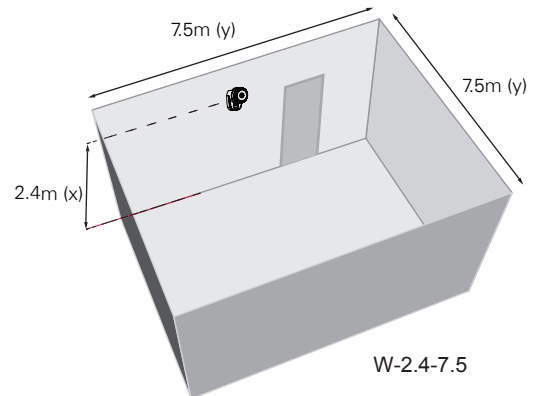

- (EN)** Drilling diameter must be adjusted to the diameter of the cable glands.
- (FR)** Le diamètre de perçage doit être adapté au diamètre des presses-étoupes.
- (DE)** Bohrdurchmesser muss dem Kabeldurchmesser angepasst sein.
- (PL)** Średnica wiercenia musi być dostosowana do średnicy dławików kablowych.
- (IT)** È necessario adattare il diametro di perforazione in base al diametro del pressacavi.

- (EN)** Cable glands must be compatible with declared cable size.
- (FR)** Les presses-étoupes doivent être adaptés à la section des câbles déclarée.
- (DE)** Kabeldurchführungen müssen mit den angegebenen Kabelabmessungen kompatibel sein.
- (PL)** Dławiki kablowe muszą pasować do zadeklarowanego rozmiaru kabla.
- (IT)** È necessario che i pressacavi siano compatibili con la dimensione del cavo indicata.



### Type A (IP21C)

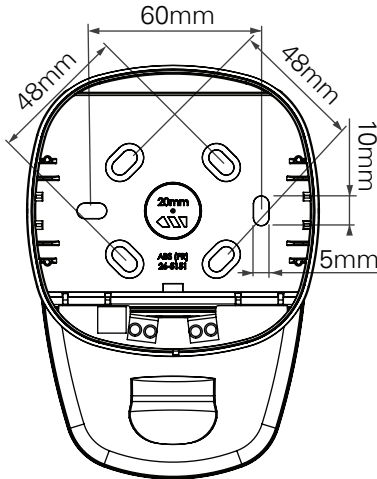

### Type B (IP66)

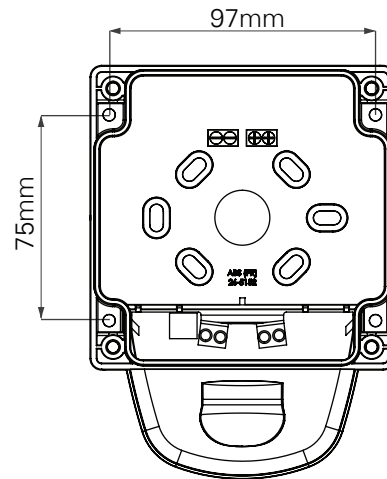

	1	2	EN54-23
1Hz	1	0	Pass
0.5Hz	0	1	Pass
High Power	1	0	Pass
Low Power	0	1	Pass

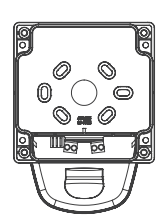
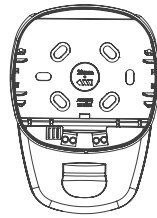
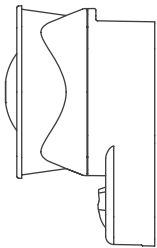
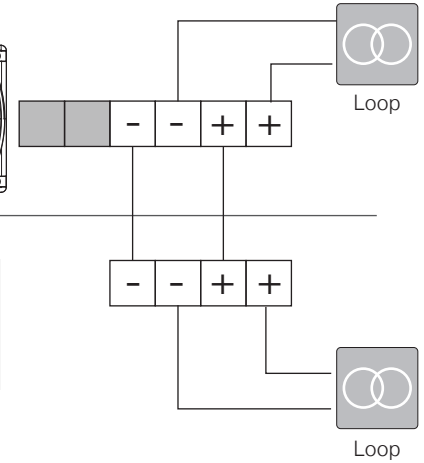
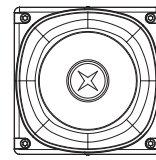
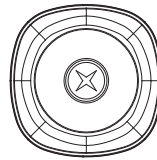

### Essential Characteristics / Caractéristiques

#### Operational Reliability / Fiabilité de Fonctionnement

Duration of operation / Durée de fonctionnement	PASS/CONFORME
Provision for external conductors / Disposition pour conducteurs extérieurs	PASS/CONFORME
Flammability of materials / Inflammabilité des matériaux	PASS/CONFORME
Enclosure protection / Indice de protection	PASS/CONFORME
Access / Accès	PASS/CONFORME
Manufacturer's adjustments / Réglages du fabricant	PASS/CONFORME
On-site adjustment of behaviour / Réglages du site	PASS/CONFORME
Requirements for software controlled devices / Exigences relatives aux dispositifs contrôlés par logiciel	PASS/CONFORME

#### Performance parameters under fire condition / Paramètres de performance en cas d'incendie

Coverage Volume / Volume de couverture	PASS/CONFORME
Variation of light output / Variance de la puissance lumineuse	PASS/CONFORME
Minimum/maximum light intensity / Intensité lumineuse minimale/maximale	PASS/CONFORME
Light colour / Couleur de la lumière	WHITE / RED /BLANC /ROUGE
Light pattern & frequency of flashing / Effets temporels lumineux et fréquence de clignotement du flash	0.5 /1Hz
Marking & Data / Marquage et données techniques	PASS/CONFORME
Synchronisation	PASS/CONFORME

#### Temperature Resistance / Résistance à la température

Dry heat (operational) / Chaleur sèche (fonctionnel)	PASS/CONFORME
Dry heat (endurance) / Chaleur sèche (endurance)	PASS/CONFORME
Cold (operational) / Froid (fonctionnel)	PASS/CONFORME

#### Humidity Resistance / Résistance à l'humidité

Damp heat, cyclic (operational) / Chaleur humide, cyclique (fonctionnel)	PASS/CONFORME
Damp heat, steady state (endurance) / Chaleur humide, continue (endurance)	PASS/CONFORME
Damp heat, cyclic (endurance) / Chaleur humide, cyclique (endurance)	PASS/CONFORME

#### Shock & Vibration & Resistance / Choc & Vibration & Resistance

Shock (operational) / Choc mécanique (fonctionnel)	PASS/CONFORME
Impact (operational) / Impact (fonctionnel)	PASS/CONFORME
Vibration (operational) / Vibration (fonctionnel)	PASS/CONFORME

#### Vibration (endurance)

Corrosion Resistance / Résistance à la corrosion	PASS/CONFORME
SO <sub>2</sub> corrosion (endurance) / Corrosion par le SO <sub>2</sub>	PASS/CONFORME

#### Electrical Stability / Stabilité électrique

EMC immunity (operational) / CEM Immunité (fonctionnel)	PASS/CONFORME
---	---------------

\* (EN) Product manual M12-004

\*\* (EN) POŻAR label must be applied if product used in Poland  
(PL) Naklejka "POŻAR" musi być użyta jeżeli produkt jest stosowany w Polsce.

Manufactured By  
Eaton Electrical Products Ltd  
Llantarnam Park, Cwmbran, Gwent, NP44 3AW, UK  
Tel: +44 (0)1633 628 500  
Fax: +44 (0)1633 866 346  
www.cooperfulleaton.com  
www.eaton.com  
Made in the UK

Eaton Industries Manufacturing GmbH  
Electrical Sector EMEA  
Route de la Longeraie 7  
1110 Morges, Switzerland  
Eaton.eu

© 2016 Eaton All rights reserved June 2016



Powering Business Worldwide